

REV	DATE	CHANGE DESCRIPTION	MOD. BY	CK1	CK2

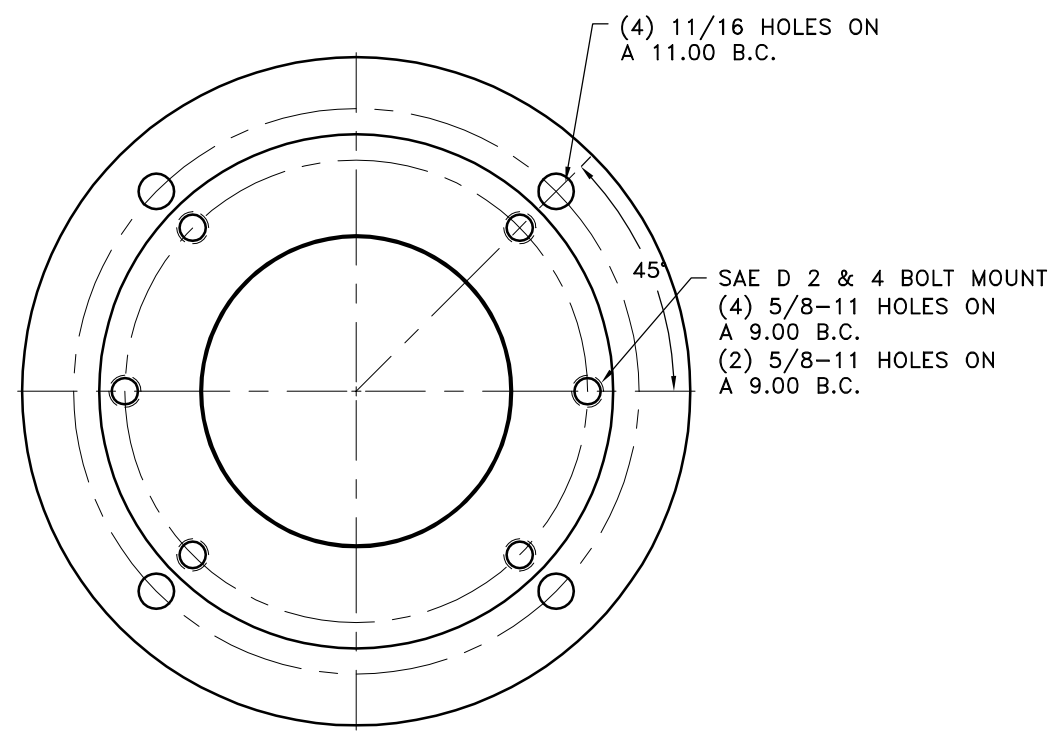
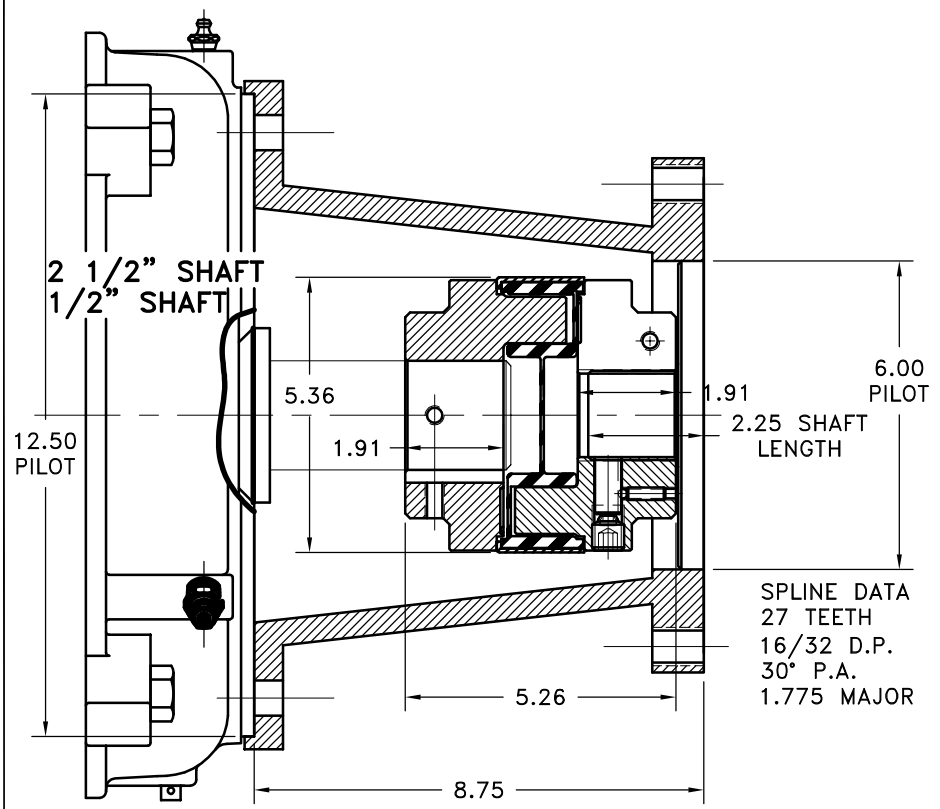

THIS DRAWING IS THE PROPERTY OF HAYES MFG. INC. AND IS LOANED SUBJECT TO THE CONDITION THAT IT SHALL NOT BE REPRODUCED, COPIED, LOANED OR OTHERWISE DISPOSED OF, DIRECTLY OR INDIRECTLY. IT SHALL BE USED AS A MEANS OF REFERENCE TO WORK FURNISHED BY THIS COMPANY ONLY AND IS NOT TO BE SUBMITTED TO OUTSIDE PARTIES FOR EXAMINATION WITHOUT OUR CONSENT.

QTY.	DESCRIPTION	PART NUMBER
2	ACCESS COVER	AC68
1	ELECTRIC MOTOR HOUSING	E68-D24
1	50 SERIES METAL RING	500-00-00-M
1	NEOPRENE INSERT	50N-00-00
1	50 SERIES COUPLING HALF	5AO-96-00
1	50 SERIES COUPLING HALF	5AO-29-00

SYMBOLS	DET.	PART NUMBER	DESCRIPTION	QTY.
<ul style="list-style-type: none"> — FLATNESS — STRAIGHTNESS — ANGULARITY — SQUARENESS — PARALLELISM — CONCENTRICITY — TRUE POSITION — ROUNDNESS — CIRCULAR RUN OUT — TOTAL RUN OUT — CYLINDRICITY — FINISH 	DO NOT SCALE DRAWING			
	TOLERANCES UNLESS OTHERWISE SPECIFIED			
	ANGLE ±1/2°			
	FRACTION ±1/32			
	DECIMAL			
	.00 ±.01			
	.000 ±.005			
	.0000 ±.0005			
	— UNLESS OTHERWISE SPECIFIED —			
	REMOVE FIRST THREAD ON ALL TAPPED HOLES			
	BREAK ALL SHARP CORNERS .010 TO .020			
	STAMP OR MARK DRAWING NO.			
HAYES MANUFACTURING INC. ®		TITLE 326TC MOTOR HOUSING W/50 SERIES		
	DRAWN BY	DATE	DRAWING NO.	
	SIETING	01-06-2009	E68-D24-050-01	
	CHECKED BY	SCALE	SHEET OF REV.	
	RJH			