

REV	DATE	CHANGE DESCRIPTION	MOD. BY	CK1	CK2

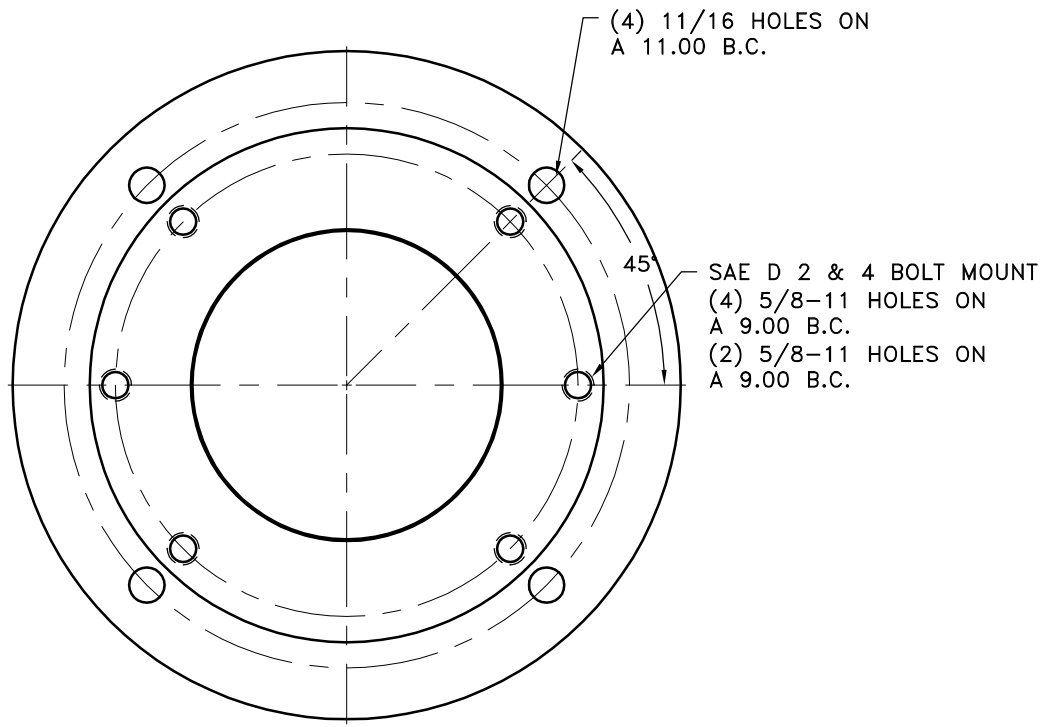
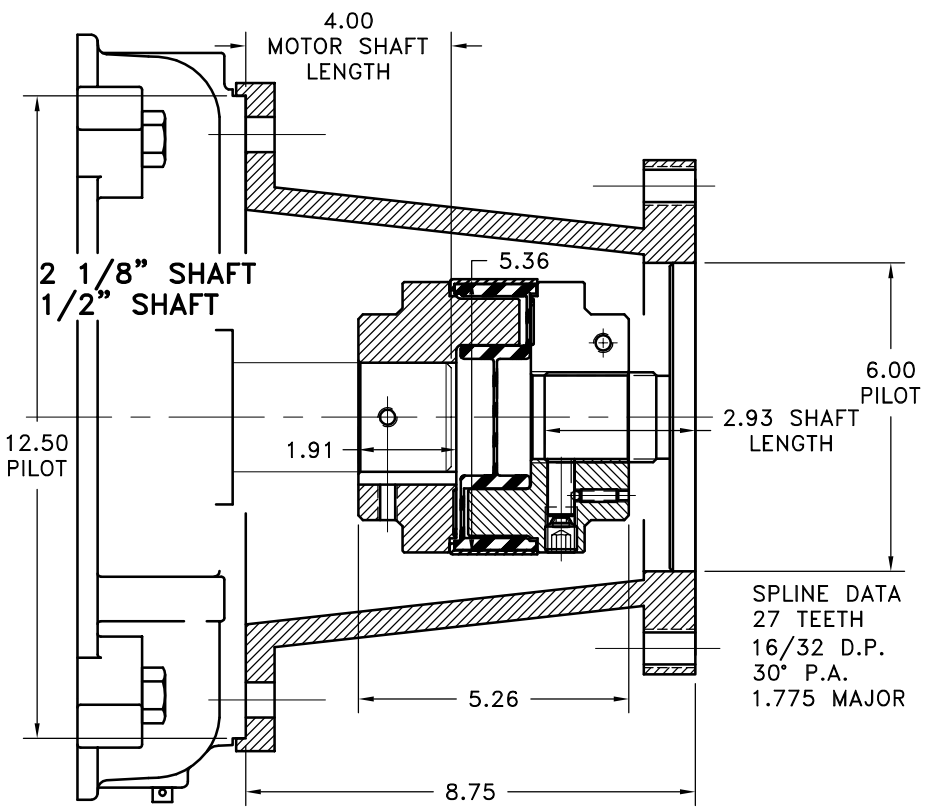

THIS DRAWING IS THE PROPERTY OF HAYES MFG. INC. AND IS LOANED SUBJECT TO THE CONDITION THAT IT SHALL NOT BE REPRODUCED, COPIED, LOANED OR OTHERWISE DISPOSED OF, DIRECTLY OR INDIRECTLY. IT SHALL BE USED AS A MEANS OF REFERENCE TO WORK FURNISHED BY THIS COMPANY ONLY AND IS NOT TO BE SUBMITTED TO OUTSIDE PARTIES FOR EXAMINATION WITHOUT OUR CONSENT.

6	AC68	ACCESS COVER	2
5	E68-D24	ELECTRIC MOTOR HOUSING	1
4	500-00-00-M	50 SERIES METAL RING	1
3	50N-00-00	NEOPRENE INSERT	1
2	5S0-90-00	50 SERIES COUPLING HALF	1
1	5S0-29-00	50 SERIES COUPLING HALF	1

SYMBOLS	DET.	PART NUMBER	DESCRIPTION	QTY.
▨ FLATNESS — STRAIGHTNESS ∠ ANGULARITY ⊥ PERPENDICULARITY ∥ PARALLELISM ⊙ CONCENTRICITY ⊕ TRUE POSITION ○ ROUNDNESS ⊖ CIRCULAR RUN OUT ⊖ TOTAL RUN OUT ⊖ CYLINDRICITY √ FINISH	DO NOT SCALE DRAWING TOLERANCES UNLESS OTHERWISE SPECIFIED 125 MAXIMUM ANGLE ±1/2° FRACTION ±1/32 DECIMAL .00 ±.01 .000 ±.005 .0000 ±.0005			
- UNLESS OTHERWISE SPECIFIED - REMOVE FIRST THREAD ON ALL TAPPED HOLES BREAK ALL SHARP CORNERS .010 TO .020 STAMP OR MARK DRAWING NO.		DRAWN BY SIETING CHECKED BY RJH	DATE 01-26-2010 SCALE	DRAWING NO. E68-D24-050-02 SHEET OF REV.