

REV	DATE	CHANGE DESCRIPTION	MOD. BY	CK1	CK2

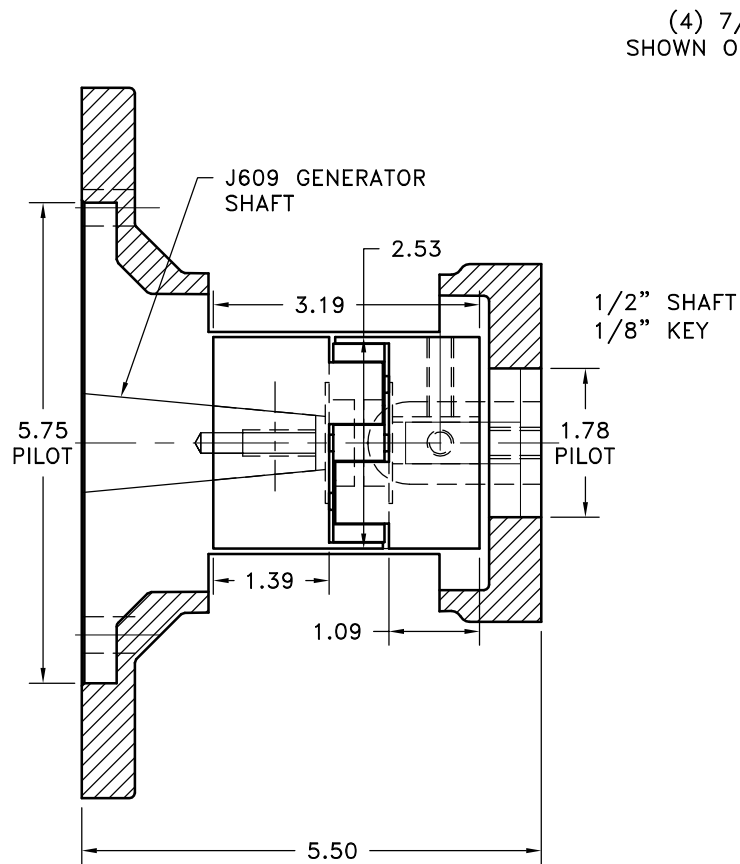

(4) 7/16 HOLES AS SHOWN ON A 6.50 B.C.

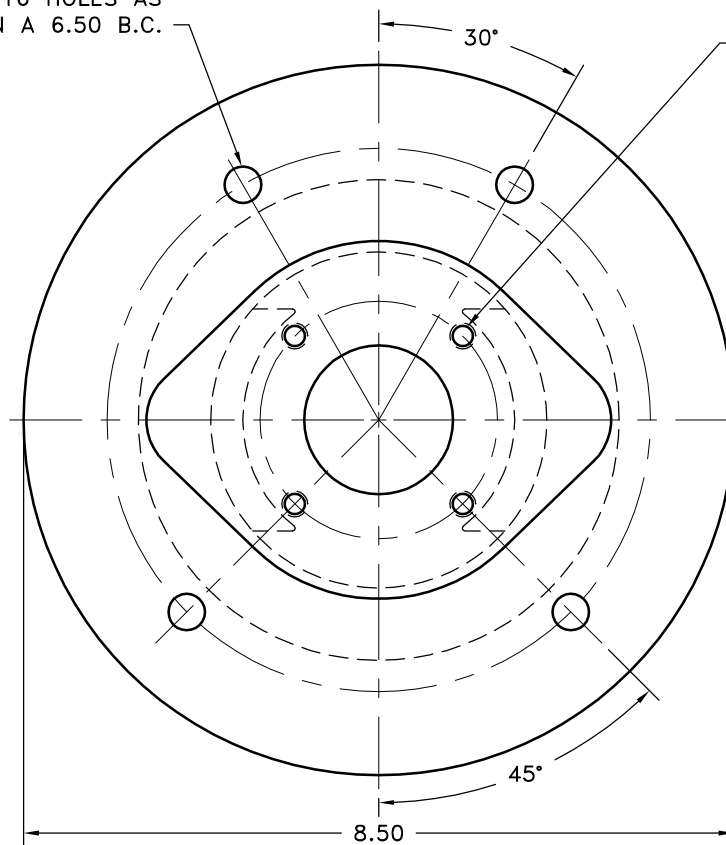

4F17 MOUNT
(4) 5/16-18 HOLES
EQ. SPACED ON A
2.84 B.C.

NOTES:
IF NEEDED, ACCESS COVERS #AC16
(2 REQUIRED)
APPROX. WEIGHT: 7 LB. 8 OZ.

THIS DRAWING IS THE PROPERTY OF HAYES MFG. INC. AND IS LOANED SUBJECT TO THE CONDITION THAT IT SHALL NOT BE REPRODUCED, COPIED, LOANED OR OTHERWISE DISPOSED OF, DIRECTLY OR INDIRECTLY. IT SHALL BE USED AS A MEANS OF REFERENCE TO WORK FURNISHED BY THIS COMPANY ONLY AND IS NOT TO BE SUBMITTED TO OUTSIDE PARTIES FOR EXAMINATION WITHOUT OUR CONSENT.

REV	DATE	CHANGE DESCRIPTION	MOD. BY	CK1	CK2
4	G-16-119-5.50	SMALL ENGINE HOUSING			1
3	L099/100N	L-SERIES INSERT			1
2	L099x1/2x1/8	L-SERIES COUPLING HUB			1
1	L100x417	L-SERIES COUPLING HUB			1

SYMBOLS	DET.	PART NUMBER	DESCRIPTION	QTY.
▨ FLATNESS — STRAIGHTNESS ∠ ANGULARITY ⊥ PERPENDICULARITY ∥ PARALLELISM ⊙ CONCENTRICITY ⊕ TRUE POSITION ○ ROUNDNESS ⊖ CIRCULAR RUN OUT ⊖ TOTAL RUN OUT ⊖ CYLINDRICITY √ FINISH	DO NOT SCALE DRAWING TOLERANCES UNLESS OTHERWISE SPECIFIED 125 MAXIMUM ANGLE ±1/2° FRACTION ±1/32 DECIMAL .00 ±.01 .000 ±.005 .0000 ±.0005			
- UNLESS OTHERWISE SPECIFIED - REMOVE FIRST THREAD ON ALL TAPPED HOLES BREAK ALL SHARP CORNERS .010 TO .020 STAMP OR MARK DRAWING NO.		DRAWN BY SIETING CHECKED BY RJH	DATE 11-12-08 SCALE	DRAWING NO. G16-119-L099/100-01 SHEET OF REV.