

REV	DATE	CHANGE DESCRIPTION	MOD. BY	CK1	CK2

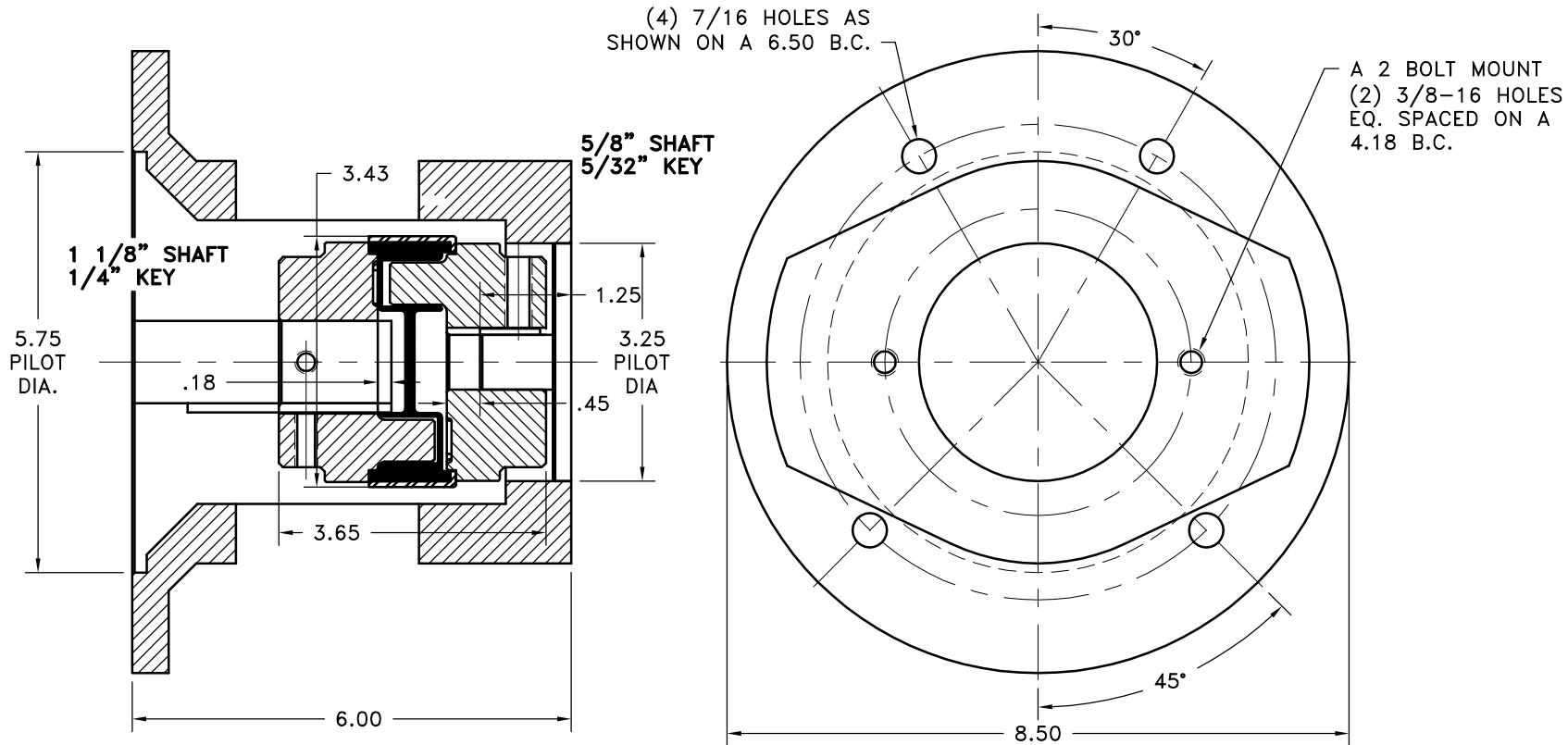

NOTES:
ACCESS COVERS #AC21 (2 REQUIRED)
APPROX. WEIGHT: 5 LB. 2 OZ.
SAE A 4 BOLT AVAILABLE.

THIS DRAWING IS THE PROPERTY OF HAYES MFG. INC. AND IS LOANED SUBJECT TO THE CONDITION THAT IT SHALL NOT BE REPRODUCED, COPIED, LOANED OR OTHERWISE DISPOSED OF, DIRECTLY OR INDIRECTLY. IT SHALL BE USED AS A MEANS OF REFERENCE TO WORK FURNISHED BY THIS COMPANY ONLY AND IS NOT TO BE SUBMITTED TO OUTSIDE PARTIES FOR EXAMINATION WITHOUT OUR CONSENT.

6	AC21	ACCESS COVER	2
5	G-21-197-6.00	SMALL ENGINE HOUSING	1
4	300-00-00-M	30 SERIES NEOPRENE INSERT	1
3	30N-00-00	30 SERIES NEOPRENE INSERT	1
2	3AO-39C-00	30 SERIES COUPLING HALF	1
1	3AO-13-00	30 SERIES COUPLING HALF	1

SYMBOLS	DET.	PART NUMBER	DESCRIPTION	QTY.
<ul style="list-style-type: none"> — FLATNESS — STRAIGHTNESS — ANGULARITY — SQUARENESS — PARALLELISM — CONCENTRICITY — TRUE POSITION — ROUNDNESS — CIRCULAR RUN OUT — TOTAL RUN OUT — CYLINDRICITY — FINISH 	DO NOT SCALE DRAWING			
	TOLERANCES UNLESS OTHERWISE SPECIFIED			
	12/5 MAXIMUM			
	ANGLE ±1/2°			
	FRACTION ±1/32			
	DECIMAL			
	.00 ±.01			
	.000 ±.005			
	.0000 ±.0005			
	— UNLESS OTHERWISE SPECIFIED —			
	REMOVE FIRST THREAD ON ALL TAPPED HOLES			
	BREAK ALL SHARP CORNERS .010 TO .020			
	STAMP OR MARK DRAWING NO.			
		DRAWN BY SIETING	DATE 03-06-08	DRAWING NO. G21-197-030-03
		CHECKED BY RJH	SCALE	SHEET OF REV.

HAYES
MANUFACTURING INC. ®

TITLE
30 SERIES SMALL ENGINE ASSY

MATERIAL

DRAWING NO.

G21-197-030-03

SHEET OF REV.